



Adequate attic ventilation is a long-standing requirement in building codes for moisture control. However, conditioned, unvented attics can reduce residential energy needs and are allowed by the code under certain conditions. Such assemblies are sometimes called cathedralized attics because, as with cathedral ceilings, the insulation is in the rafters and/or roof deck. The primary benefit of cathedralized attics is the ability to locate HVAC ducts inside conditioned space, where duct leaks and heat losses/gains are not detrimental to the home's energy bill.

Section 806.4 of the 2006 International Residential Code® (IRC) has requirements for conditioned attics. The overall insulation level in the roof assembly must meet the baseline requirements for energy efficiency as given in Section N1102 (or IECC, Section 402). Additionally, there are requirements related to the arrangement of the insulation so as to prevent moisture condensation in the roof assembly. In all but Climate Zones 2B and 3B, the IRC requires air-impermeable insulation in direct contact with the underside of the roof deck. A combination of an air-impermeable insulation and air-permeable insulation directly below it is permitted.

In zones 3 through 8, the IRC defines a *condensing surface* as the underside of the air-impermeable insulation mentioned above or, if there is no air-impermeable layer (allowed only in zone 3B), the underside of the roof deck. There must be sufficient insulation above the condensing surface to maintain the monthly average temperature of that surface at or above 45°F. The required amount of insulation above the condensing surface, which may be any combination of air-impermeable insulation under the roof deck and insulation above the roof deck, can be determined with the following equation.

$$R_{\text{above}} / R_{\text{below}} \# (45 - T_{\text{outside}}) / (T_{\text{inside}} - 45)$$

For example, if the coldest average monthly outdoor temperature is 30°F, with the code-specified inside temperature assumption of 68°F, we get:

$$R_{\text{above}} / R_{\text{below}} \# (45 - 30) / (23)$$

or,

$$R_{\text{above}} / R_{\text{below}} \# 0.6522$$

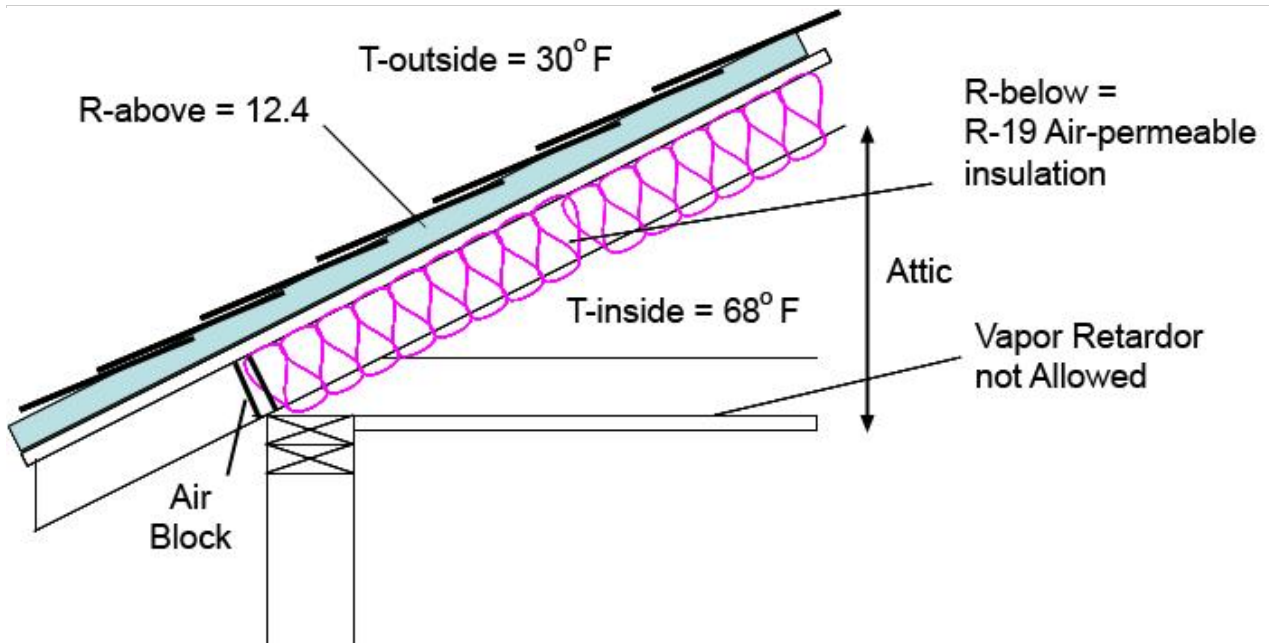



For this example, if the insulation below the condensing surface is R-19, the total insulation above the condensing surface (which can be a combination of air-impermeable insulation under the roof deck and/or any type of insulation above the roof deck) must be at least  $0.6522 \times 19$  or R-12.4. This gives a total roof/ceiling insulation R-value of  $19 + 12.4 = 31.4$ . The insulation requirements in Section 806.4 of the IRC are independent of insulation requirements for energy efficiency, which may be higher - Section 806.4 only regulates the placement and arrangement of insulation to mitigate the potential for water condensation.

The IRC also prohibits a vapor retarder on the attic floor of conditioned attics so that any moisture that may build up in the attic can dissipate into the house. For roof assemblies in warm humid climates in the Southeastern U.S., extra requirements apply to assist in drying of the roof deck. For asphalt roofing shingles, a vapor retarder with a perm rating of 1.0 or less is required to be installed over the roof sheathing (see Figure). If wood shingles or shakes are used, a ¼-inch air gap must be left above the roof sheathing but below the shingles/shakes and roofing felt.

Note that the [2007 Supplement to the IRC](#) simplifies these requirements, eliminating the need for calculations. In the 2007 IRC, one of the three options that follow would meet the requirement:

1. Air-impermeable insulation only - air-impermeable insulation shall be applied in direct contact to the underside of the structural roof sheathing.
2. Air-permeable insulation only - in addition to the air-permeable insulation installed directly below the structural sheathing, rigid board or sheet insulation shall be installed directly above the structural roof sheathing as specified in Table 1 for condensation control.
3. Air-impermeable and air-permeable insulation - air-impermeable insulation shall be applied in direct contact to the underside of the structural roof sheathing as specified in Table 1 for condensation control. The air-permeable insulation shall be installed directly under the air-impermeable insulation.

#### **Table 1. Insulation for Condensation Control**



Climate Zone	Minimum rigid board or air-impermeable insulation R-Value
2B and 3B with tile roof only	0
1, 2A, 2B, 3A, 3B, 3C	R-5
4C	R-10
4A, 4B	R-15
5	R-20
6	R-25
7	R-30
8	R-35

## Plan Review (2006 IRC)

1. Verify that the total insulation R-value proposed for the roof assembly meets or exceeds the energy code compliance documentation.
2. For all but Climate Zones 2B and 3B, verify that the insulation in contact with the underside of the roof deck is air-impermeable.
3. For Climate Zones 3 through 8, verify that the ratio of R-values above and below the condensing surface will maintain the condensing surface temperature at 45°F or greater. Require calculations from the designer to verify this temperature.
4. In locations that are *warm-humid* as defined in Chapter 11 of the IRC, verify that a vapor retarder is called out immediately above the roof structural sheathing for asphalt shingle roofs and that a ¼-inch air gap is called out for wood shingle roof systems.

## Field Inspection (2006 IRC)

1. Verify that roof insulation installed under the roof sheathing is well supported and in substantial contact with the sheathing (if fiberglass batt insulation). For air-impermeable insulation, verify that the installed insulation is the correct thickness to meet the R-value requirement called out on the plans.
2. Verify that the correct R-value of insulation is installed on top of the roof sheathing if required by code.
3. Verify that a vapor retarder is installed on top of the roof sheathing for asphalt roofs in humid climate zones.
4. Verify that the blocking between trusses and roof members are calked and sealed and that any penetration through the roof sheathing is sealed using an approved sealant.

## Code Citations\*

### 2006 IRC, Section R806.4 Conditioned attic assemblies

Unvented conditioned attic assemblies (spaces between the ceiling joists of the top story and the roof rafters) are permitted under the following conditions:

1. No interior vapor retarders are installed on the ceiling side (attic floor) of the unvented attic assembly.
2. An air-impermeable insulation is applied in direct contact to the underside/interior of the structural roof deck. "Air-impermeable" shall be defined by ASTM E 283.
3. In the warm humid locations as defined in N1101.2.1:



1. For asphalt roofing shingles: A 1 perm or less vapor retarder (determined using Procedure B of ASTM E 96) is placed to the exterior of the structural roof deck; i.e. just above the roof structural sheathing.
2. For wood shingles and shakes: a minimum continuous ¼-inch vented air space separates the shingles/shakes and the roofing felt placed over the structural sheathing.
4. In zones 3 through 8 as defined in N1101.2 sufficient insulation is installed to maintain the monthly average temperature of the condensing surface above 45°F. The condensing surface is defined as either the structural roof deck or the interior surface of an air-impermeable insulation applied in direct contact to the underside/interior of the structural roof deck. "Air-impermeable" is quantitatively defined by ASTM E 283. For calculation purposes, an interior temperature of 68°F is assumed. The exterior temperature is assumed to be the monthly average outside temperature.

\*ICC Reference and link Copyright, 2006, [International Code Council](#), Inc. Falls Church, Virginia. All rights reserved. 2006 *International Residential Code*. **PNNL-SA-57101**